

## MaKey MaKey

Recommended for students Grades 3+  
Activity must have internet access.

**If you have any corrections or suggestions to make this write up better, please let us know [HERE](#). We want to hear from you!**

For more information on digital literacy, or for additional resource,, please refer to the session presentation [HERE](#).

Science	Practical & Applied Arts	English Language Arts
OM1.1 & OM1.2 MP2.1 EL6.1, EL6.2 & EL6.3 CE9.1, CE9.2 & CE9.3	7A, 7B & 7C Design Thinking 8 Electrical Safety 9 Debugging Circuits 11A & 11B Basic Electricity 13A, 13B & 13C Electronic Components 14A & 14B Drawing Circuits 25A & 25B Psudeocode 26A & 26B Block Based Coding 27 Syntax and Organization 29 Debugging Code	CCX.1 & CCX.2 (X=1-5) CRY.4, CRY.7 CCY.4, CCY.8 (Y=6-9)

Arts Education
CPZ.5, CPZ.6 (Z=1-5) CP6.7, CP6.8, CP6.9, CP6.11 CP7.7 CP8.8, 8.11 CP9.7, CP9.8, CP9.11

### Activity in this Package!

Activity 5: [Gummy Piano](#)

### Additional Resources

[Educator Resources- MaKey MaKey](#)

- Includes Educator Guide, Sample Lesson Plans, and Sample Lesson Plans for Lego

[Sparkfun QuickStart Guide](#)

[Makerspace For Education](#)

***Big Ideas***

- Students will explore the parts of a simple circuit
- Students will create a simple circuit
- Students will explore insulators and conductors
- Students will participate in the engineering and design process
- Students will explore different tones of a piano and other various musical instruments.

***Safety Considerations***

- If using edible materials, please be cautious of allergies.
- Electronics can cause shock and must be used with caution.
- Be cautious of using sharps.
- It is always good to have web programming preloaded, and to take care with what students are searching on the internet.

***Background Information***

What is in the box?

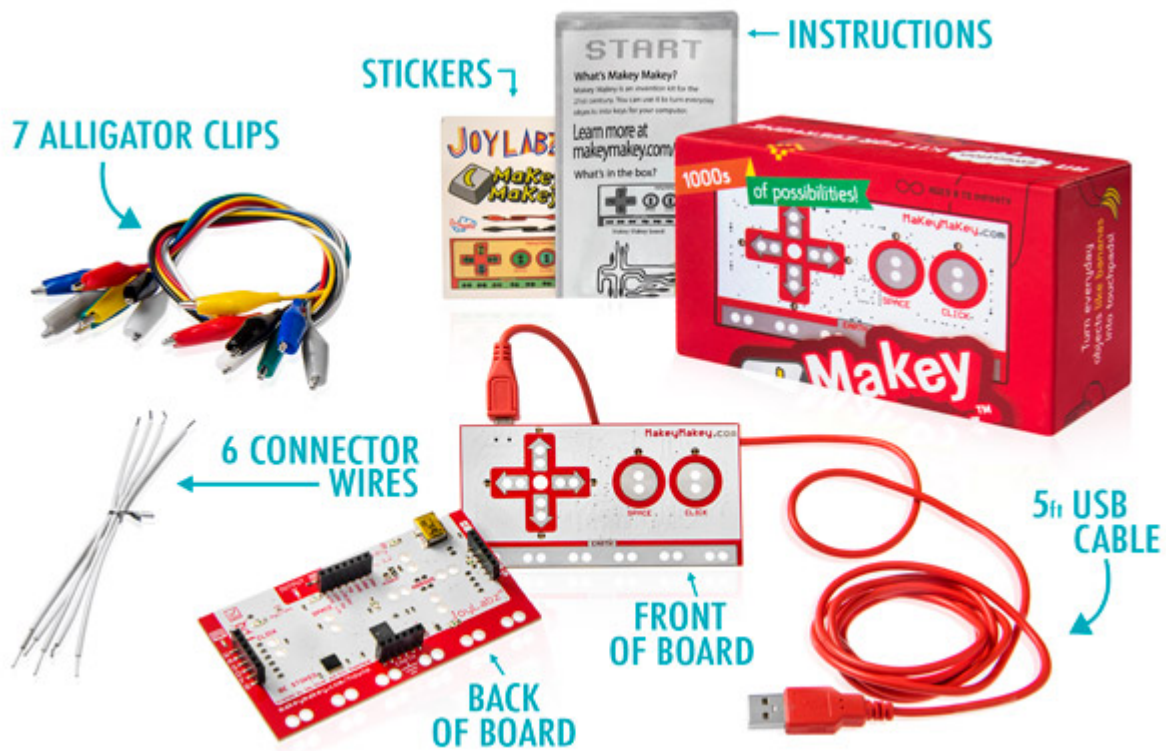

Okay no stickers. We took them out.

**MaKey MaKey: An Invention Kit for Everyone** is an electronic invention tool and toy that allows users to connect everyday objects to computer programs. Using a [circuit board](#), alligator clips, and a [USB cable](#), the toy uses [closed loop electrical signals](#) to send the computer either a keyboard stroke or mouse click signal. This function allows the MaKey MaKey to work with any computer program or [webpage](#) that accepts keyboard or mouse click inputs. Essentially, a MaKey MaKey can replace your keyboard and mouse!

### What is electricity?

Electricity is the set of physical phenomena associated with the presence and motion of matter that has a property of electric charge. In early days, electricity was considered as being not related to magnetism.

The presence of an electric charge, which can be either positive or negative, produces an electric field. The movement of electric charges is an electric current and produces a magnetic field.

Electrical power is usually generated by electro-mechanical generators driven by steam produced from fossil fuel combustion, or the heat released from nuclear reactions; or from other sources such as kinetic energy extracted from wind or flowing water.

Since electrical energy cannot easily be stored in quantities large enough to meet demands on a national scale, at all times exactly as much must be produced as is required. This requires electricity utilities to make careful predictions of their electrical loads, and maintain constant coordination with their power stations. A certain amount of generation must always be held in reserve to cushion an electrical grid against inevitable disturbances and losses.

### What is a circuit?

An electronic circuit is composed of individual electronic components, such as [resistors](#), [transistors](#), [capacitors](#), [inductors](#) and [diodes](#), connected by conductive [wires](#) or [traces](#) through which electric current can flow. The combination of components and wires allows various simple and complex operations to be performed: signals can be amplified, computations can be performed, and data can be moved from one place to another.

### What are the parts of a circuit?

An electrical circuit is a path or line through which an electrical current flows. The path may be closed (joined at both ends), making it a loop. A closed circuit makes electrical current flow possible. It may also be an open circuit where the electron flow is cut short because the path is broken. An open circuit does not allow electrical current to flow.

Below is a basic set of symbols that you may find on circuit diagrams

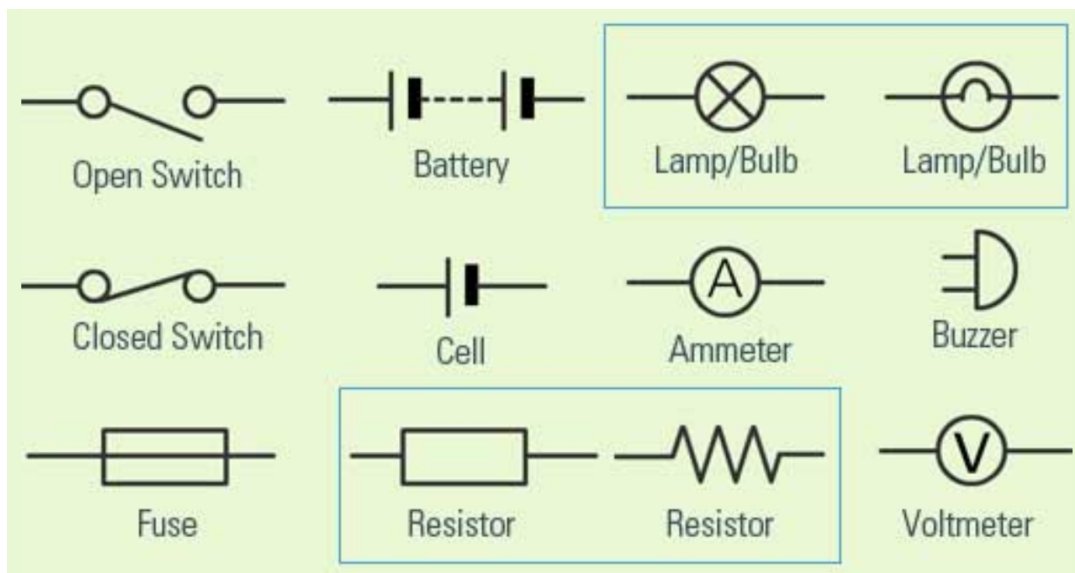

It is very important to know the basic parts of a simple circuit and the symbols that relate to them. A simple circuit has conductors, a switch, a load and a power source. Here are the functions of each part:

### Conductors:

These are usually copper wires with no insulation. They make the path through which the electricity flows. One piece of the wire connects the current from the power source (cell) to the load. The other piece connects the load back to the power source.

**Switch:**

The switch is simply a small gap in the conductor where you can close or open the circuit. When the switch is closed, the circuit is closed and electricity flows.

**The Load:**

The load is a small light bulb or buzzer that lights when the circuit is turned on. The load is also known as a resistor.

**Cell:**

The power source is a cell. (Note that more than one cell put together is known as a battery)

The diagram below shows how a basic circuit looks like.

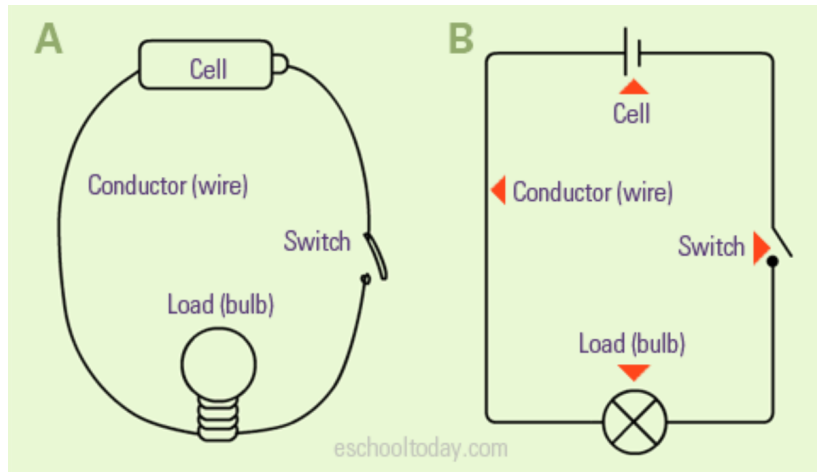

It is important to draw circuits with clean straight lines, as shown in diagram B. Avoid realistic sketches. It is important to know that a circuit can have more than the basic components in the diagram. It can have two or more batteries or two or more bulbs.

**Series circuits**

A series circuit is one that has more than one resistor, but only one path through which the electricity (electrons) flows. From one end of the cell (battery), the electrons move along one path with NO branches, through the resistors, to the other end of the cell. All the components in a series circuit are connected end-to-end.

A resistor in a circuit is anything that uses some of the power from the cell. In the example below, the resistors are the bulbs. In a series circuit, the components are arranged in a line, one after the other.

Take a look at the diagram below:

The schematic drawing is a better way to draw a series circuit.

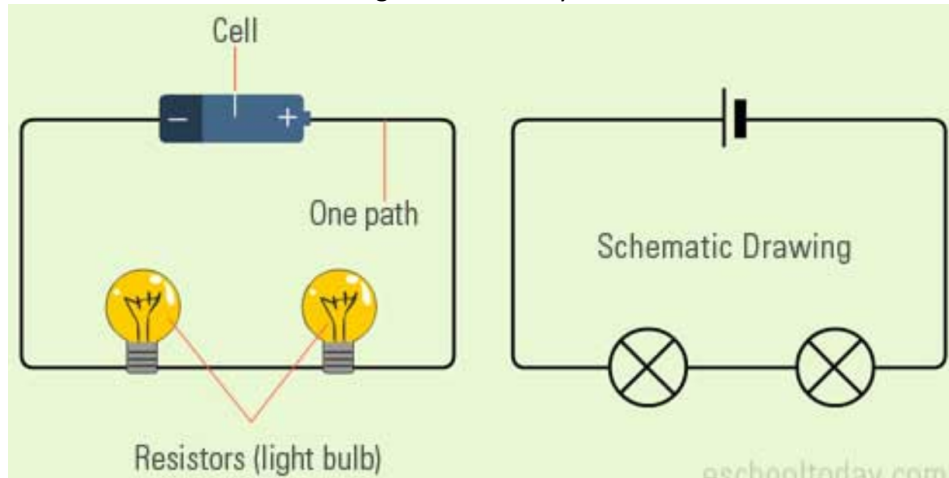

Each time there is damage (break) in any one of the resistors the entire circuit will not function. For example, if one light bulb goes out, all the other lights will go off because the electricity path in the broken bulb is cut off.

Do you put Christmas lights on the trees at home during Christmas? If the lights are in a series circuit, one burned out bulb will keep all the lights off. That is one disadvantage of series circuits. One advantage though is that you will always know if there is a break in a series circuit. If there are many bulbs in a circuit with a battery (cell), it is very likely that the light will be dimmer because many resistors are acting on the same voltage of power from the battery.

### **Parallel circuits**

In a parallel circuit, there is more than one resistor (bulb) and they are arranged on many paths. This means electricity (electrons) can travel from one end of the cell through many branches to the other end of the cell.

Look at the illustration below involving two resistors in a parallel circuit:

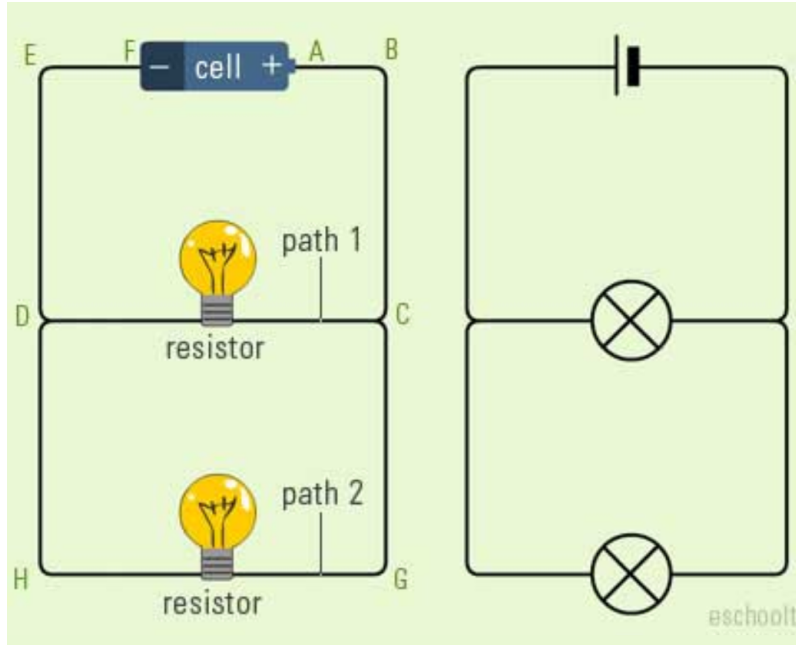

You will notice from the above that there is more than one path:

PATH 1: A-B-C-D-E-F and back to A.

PATH 2: A-B-C-G-H-D-E-F and back to A.

From the above, it is clear that electricity from the cell can take either path A or Path B to return to the cell. The great thing about parallel circuits is that, even when one resistor (bulb) burns out, the other bulbs will work because the electricity is not flowing through one path.

Think of all the light bulbs in your home. If one bulb burns out, the other bulbs in the rooms still work. Another great thing is that the bulbs in a parallel circuit do not dim out like the case in series circuits. This is because the voltage across one branch is the same as the voltage across all other branches. What is a short circuit?

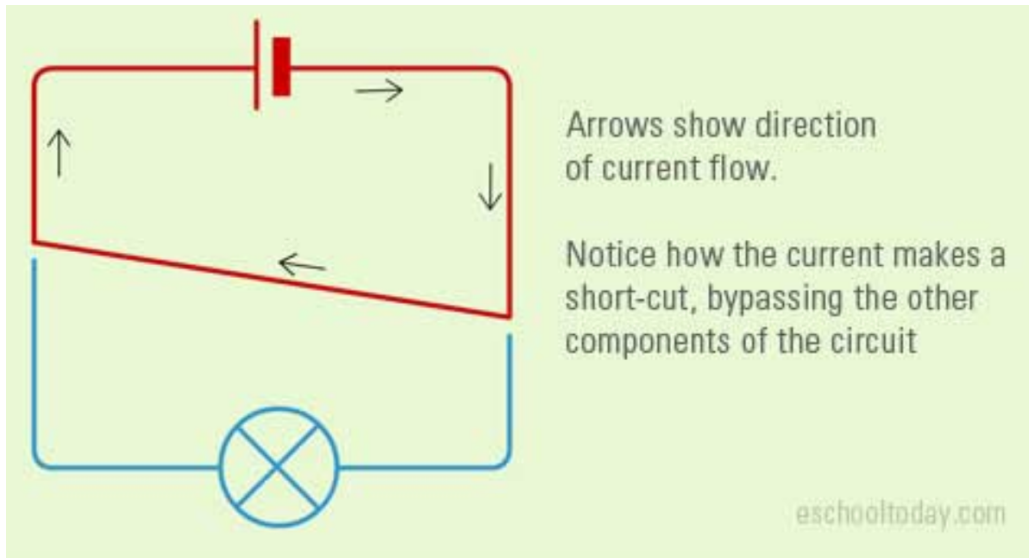

A simple, well-designed circuit, as discussed earlier, has a cell providing current along a path (wire), to a load (resistor) and back to the other end of the cell as shown in this diagram.

As the voltage gets to the resistor (load), there is a power drop, because the resistor uses some of the electricity up to produce heat and light. This means that the voltage that ends up at the other side of the cell is reduced.

In a short circuit, there is no load. For many reasons, the wires in a circuit can find a short-cut, bypassing the load (and other components). This causes the same voltage from the cell to flow to the other end of the cell. When this happens the high voltage causes the wires to heat up and catch fire.

Can you think of some reasons why there could be a short circuit?

Here are a few:

- Wires may lose their insulation and touch each other in the circuit
- There could be a fault (improper wiring) in a device
- Intentionally connecting both ends of a cell / battery with wires. This causes a massive drain of electricity and the battery loses its power in a very short time.

A short circuit can cause heating, melting of wires, harmful smoke and smell, and blinding light (like what you see during welding)

<https://eschooltoday.com/science/electricity/what-is-an-electrical-circuit.html>

### **Activity 5: Gummy Piano**

What do gummy worms, computers, and pianos have in common? Nothing, except when you put them all together you can create a piano on the computer controlled by a gummy worm!

## Materials

- 1 gummy worm per group of two students.
- 1 small container of playdoh per group of two students.
- 1 controller printout per group of two students (attached).

## Equipment

- 1 MaKey Makey classic kit per group of two students.
- 1 computer per group of two students.
  - o Computer must be preloaded with: <https://makeymakey.com/piano/>

## Procedure

### PRELESSON

- Make sure you have enough paper controllers printed

It is time to get started! Before we get started I have some questions. I hear you guys have learned a lot about... *\*whisper\** sound. Who can tell me, **what is sound?** *Sound is vibrations that move through a medium, like air, that we are able to hear once they reach our ears.* Okay, okay. You're all so smart! So we know that there are natural sounds and artificial sounds, **but I am not sure what the difference is, do you?** *Natural sounds are one that exist in nature, such as birds and creeks. Artificial sounds are ones that humans have created! Such as the sound of traffic or pianos.* Phew! Thank you! Well that reminds me, today we are going to explore the world of this artificial sounds, and we are going to create a piano! But this isn't just any piano, this is a piano that we control with playdoh arrows and a gummy worm!

1. Group students in groups of 2. Hand each group a print out of a controller and playdoh.

First we need to create a controller for our digital piano! Using your playdoh, make 4 arrows! Place the arrows on your controller, but be careful! Don't let your arrows touch!

2. Hand each group a MaKey Makey. They are going to need to connect the classic board using alligator clips to the playdoh! You want to connect the "up" arrow on the MaKey Makey board to the up arrow that you created! Same goes for the "left", "right", and "down" arrow.

**NOTE: Alligator clips are pinchy! Be careful not to close them on your fingers.**

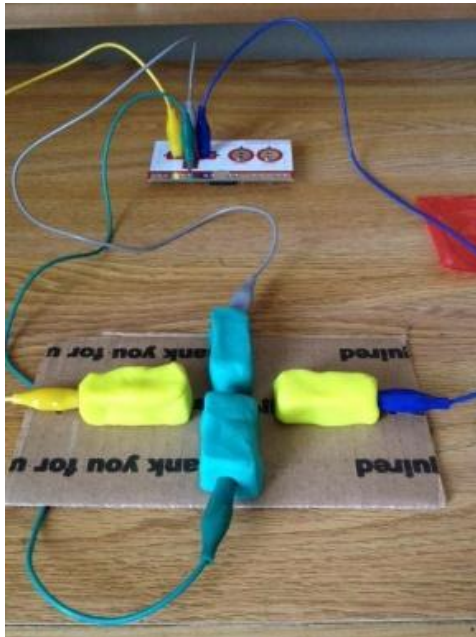

3. Hand out computers. Next you will need to plug your MaKey Makey into the computer! Once plugged in, you will need to test your buttons!! So gently press on the buttons that you created. **What is the difference between pressing your “up” button and the “down” button? Do they make the same sound? No! They are different tones. When we press different buttons, the computer artificially knows to create different tones! Can everyone play their lowest tone? Now their highest?**
4. Hand each group a gummy worm. We are going to connect your gummy worm to the “space” portion of your MaKey Makey board! Now you will be able to play another key- but on a gummy worm!

**NOTE: Some students may be allergic to gummy worms. If this is the case they can make a gummy worm out of playdoh.**

**NOTE: Remind students that we don’t eat science, and that these worms are for experimentation only. No nibbles allowed!**

Let the students play with the piano.

#### CLEAN UP

Have the students pack up their kits. **MAKE SURE YOU INSPECT EACH KIT FOR ALL THE PARTS BEFORE YOU LEAVE THE ROOM.** It is easiest if you have the students line up with the kits and bring them to you, then you can check each kit and put them away. It also keeps the students accountable for making sure they have all their parts when they return the kits.

### **Troubleshooting**

- Are somebody's hands just too dry? Try putting out a damp sponge for people with dry hands.
- Have you clicked on the program to bring browser focus to it?
- Is your sound turned on? Try pushing the arrow keys directly on your keyboard and watch the piano on the screen.
- Is the MaKey MaKey plugged in USB?
- Are you grounded? You have to be touching ground AND touching the arrow input both at the same time.

### ***Follow up***

### **Extensions and Accommodations**

Extensions

- Challenge students to see what else in their classroom can be used with the MaKey MaKey

**NOTE: Be careful when clipping different objects to the MaKey MaKey. If it doesn't fit in the clip, choose something else to test!**

### **Future...**

Would you do this activity again? Did it turn out how you planned? Do you have any recommendations for the next person who chooses to do this activity?

### **References**

[https://en.wikipedia.org/wiki/Makey\\_Makey](https://en.wikipedia.org/wiki/Makey_Makey)

[https://en.wikipedia.org/wiki/Electricity#Production\\_and\\_uses](https://en.wikipedia.org/wiki/Electricity#Production_and_uses)

[https://en.wikipedia.org/wiki/Electronic\\_circuit](https://en.wikipedia.org/wiki/Electronic_circuit)

<https://eschooltoday.com/science/electricity/what-is-an-electrical-circuit.html>

